

The Sorelle

DOUBLE STOREY

Suits 8.9m frontage

BEDS	BATHS	CAR SPACES
5	3	2

Ground Floor Area	83.74m ²
First Floor Area	75.24m ²
Garage	30.25m ²
Porch	4.22m ²
Alfresco	6.30m ²
Overall Width	6.975m ²
Overall Length	14.75m ²

HOUSE	
199.75m ²	21.5 sq

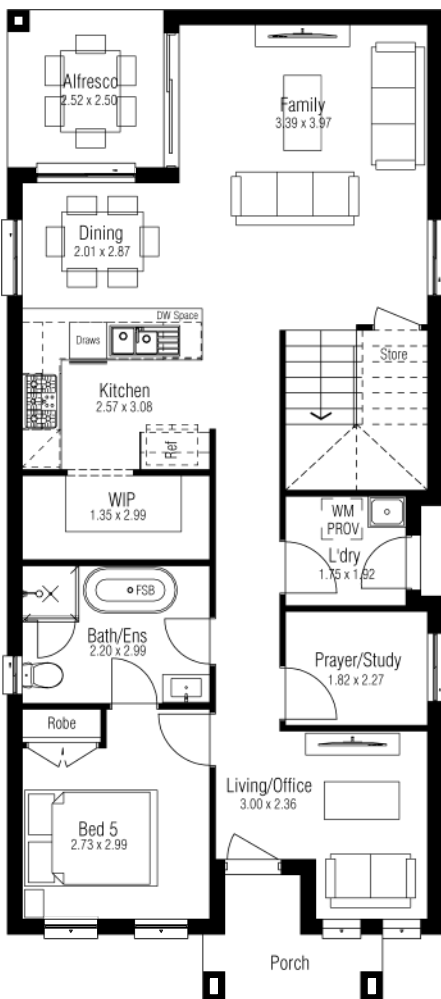

Ground Floor plan

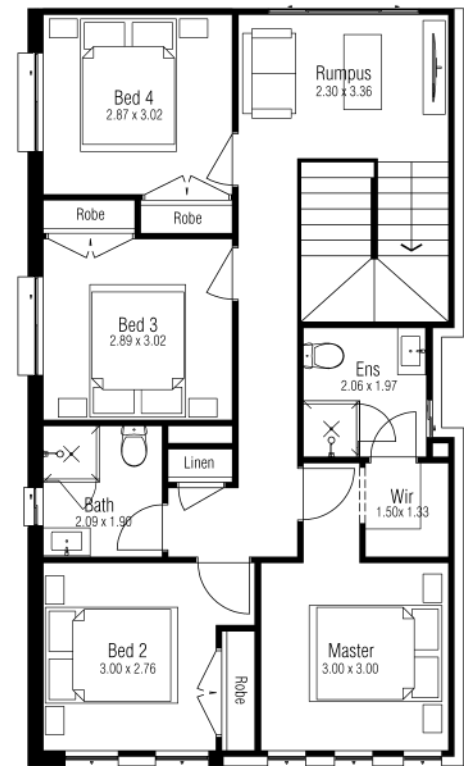
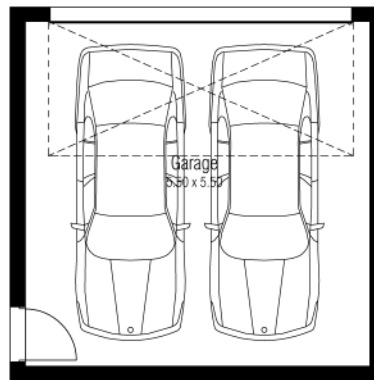

First Floor plan

Disclaimer: All photographs, facades, colour schemes, floor plans and dimensions are for illustrative purposes only and may vary slightly to the end product.